



DN168223X

Refrigerator

BEKO

Please read this user manual first!

Dear Customer,

We hope that your product, which has been produced in modern plants and checked under the most meticulous quality control procedures, will provide you an effective service.

Therefore, read this entire user manual carefully before using the product and keep it as a reference. If you handover the product to someone else, give the user manual as well.

The user manual will help you use the product in a fast and safe way.

- Read the manual before installing and operating the product.
- Make sure you read the safety instructions.
- Keep the manual in an easily accessible place as you may need it later.
- Read the other documents given with the product.

Remember that this user manual is also applicable for several other models. Differences between models will be identified in the manual.

Explanation of symbols

Throughout this user manual the following symbols are used:

 Important information or useful tips.

 Warning against dangerous conditions for life and property.

 Warning against electric voltage.

CONTENTS

1 Your Refrigerator	3	5 Using your refrigerator	13
		Indicator Panel.....	13
		Temperature setting button.....	22
2 Important Safety Warnings	4	Setting the temperature of your refrigerator.....	22
Intended use	4	Dual cooling system	22
General safety	4	Recommendations for preservation of frozen food	23
For products with a water dispenser; ..	6	Defrosting.....	23
Child safety.....	6	Placing the food	23
Package information.....	6	Deep-freeze information	24
HCA warning	7	Egg section	24
Things to be done for energy saving..	7	Description and cleaning of odor filter:	25
Recommendations for the fresh food compartment.....	8	Water Dispenser	26
		Blue light	28
3 Installation	9	Sliding storage container	28
Points to be paid attention to when the relocation of the refrigerator	9	Rotary storage container	29
Before you start the refrigerator,.....	9	Auto Icematic	30
Electrical connection.....	9	Icematic and ice storage container ..	31
Disposing of the packaging	10	Making ice.....	32
Disposing of your old refrigerator	10	Humidity-controlled crisper (Ever Fresh)	32
Placing and Installation	10	Ice-cream machine.....	34
Adjusting the legs	11		
Changing the illumination lamp	11	6 Maintenance and cleaning	36
Door Open Warning.....	11	Protection of plastic surfaces	36
4 Preparation	12		
		7 Troubleshooting	37

1 Your Refrigerator

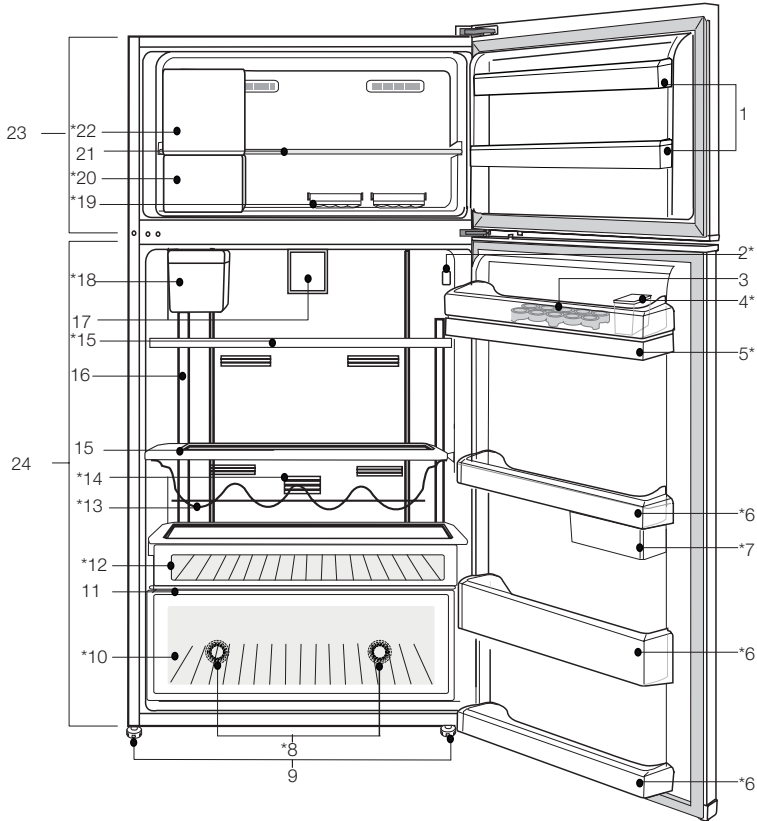

- | | |
|--|---|
| <ul style="list-style-type: none"> 1. Door shelves of the freezer compartment 2. Temperature setting indicator 3. Egg section 4. Water dispenser filling tank 5. Water dispenser reservoir 6. Door shelves of fridge compartment 7. Sliding and rotary storage containers 8. Blue light 9. Adjustable legs 10. Crisper 11. Crisper cover 12. Breakfast compartment 13. Bottle shelf | <ul style="list-style-type: none"> 14. Odor filter 15. Glass shelves of fridge compartment 16. Illumination glass 17. Impeller 18. Automatic Icematic water tank 19. Icebox 20. Ice storage container 21. Freezer compartment glass shelf 22. Ice-cream making machine / Quick Freeze compartment 23. Freezer compartment 24. Fridge compartment |
|--|---|

***optional**

ⓘ Figures in this user manual are schematic and may not correspond exactly to your product. If the subject parts are not included in the product you have purchased, then it is valid for other models.

2 Important Safety Warnings

Please review the following information. Failure to observe this information may cause injuries or material damage. Otherwise, all warranty and reliability commitments will become invalid.

The service life of your product is 10 years. During this period, original spare parts will be available to operate the product properly.

Intended use

This product is intended to be used

- indoors and in closed areas such as homes;
- in closed working environments such as stores and offices;
- in closed accommodation areas such as farm houses, hotels, pensions.
- It should not be used outdoors.

General safety

- When you want to dispose/scrap the product, we recommend you to consult the authorized service in order to learn the required information and authorized bodies.
- Consult your authorized service for all your questions and problems related to the refrigerator. Do not intervene or let someone intervene to the refrigerator without notifying the authorised services.
- For products with a freezer compartment; Do not eat cone ice cream and ice cubes immediately after you take them out of the freezer compartment! (This may cause frostbite in your mouth.)
- For products with a freezer compartment; Do not put bottled and canned liquid beverages in the freezer compartment. Otherwise, these may burst.

- Do not touch frozen food by hand; they may stick to your hand.
- Unplug your refrigerator before cleaning or defrosting.
- Vapor and vaporized cleaning materials should never be used in cleaning and defrosting processes of your refrigerator. In such cases, the vapor may get in contact with the electrical parts and cause short circuit or electric shock.
- Never use the parts on your refrigerator such as the door as a means of support or step.
- Do not use electrical devices inside the refrigerator.
- Do not damage the parts, where the refrigerant is circulating, with drilling or cutting tools. The refrigerant that might blow out when the gas channels of the evaporator, pipe extensions or surface coatings are punctured causes skin irritations and eye injuries.
- Do not cover or block the ventilation holes on your refrigerator with any material.
- Electrical devices must be repaired by only authorised persons. Repairs performed by incompetent persons create a risk for the user.
- In case of any failure or during a maintenance or repair work, disconnect your refrigerator's mains supply by either turning off the relevant fuse or unplugging your appliance.
- Do not pull by the cable when pulling off the plug.
- Place the beverage with higher proofs tightly closed and vertically.
- Never store spray cans containing flammable and explosive substances in the refrigerator.

- Do not use mechanical devices or other means to accelerate the defrosting process, other than those recommended by the manufacturer.
- This product is not intended to be used by persons with physical, sensory or mental disorders or unlearned or inexperienced people (including children) unless they are attended by a person who will be responsible for their safety or who will instruct them accordingly for use of the product

- Do not operate a damaged refrigerator. Consult with the service agent if you have any concerns.
- Electrical safety of your refrigerator shall be guaranteed only if the earth system in your house complies with standards.

- Exposing the product to rain, snow, sun and wind is dangerous with respect to electrical safety.
- Contact authorized service when there is a power cable damage to avoid danger.
- Never plug the refrigerator into the wall outlet during installation. Otherwise, risk of death or serious injury may arise.
- This refrigerator is intended for only storing food items. It must not be used for any other purpose.

- Label of technical specifications is located on the left wall inside the refrigerator.
- Never connect your refrigerator to electricity-saving systems; they may damage the refrigerator.
- If there is a blue light on the refrigerator, do not look at the blue light with optical tools.
- For manually controlled refrigerators, wait for at least 5 minutes to start the refrigerator after power failure.

- This operation manual should be handed in to the new owner of the product when it is given to others.
- Avoid causing damage on power cable when transporting the refrigerator. Bending cable may cause fire. Never place heavy objects on power cable.
- Do not touch the plug with wet hands when plugging the product.

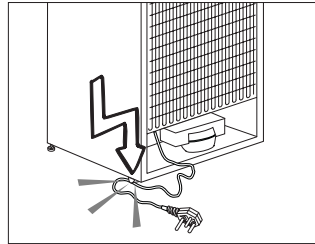

- Do not plug the refrigerator if the wall outlet is loose.
- Water should not be sprayed on inner or outer parts of the product for safety purposes.
- Do not spray substances containing inflammable gases such as propane gas near the refrigerator to avoid fire and explosion risk.
- Never place containers filled with water on top of the refrigerator; in the event of spillages, this may cause electric shock or fire.
- Do not overload the refrigerator with food. If overloaded, the food items may fall down and hurt you and damage refrigerator when you open the door.
- Never place objects on top of the refrigerator; otherwise, these objects may fall down when you open or close the refrigerator's door.

- As they require a precise temperature, vaccines, heat-sensitive medicine and scientific materials and etc. should not be kept in the refrigerator.
- If not to be used for a long time, refrigerator should be unplugged. A possible problem in power cable may cause fire.
- The plug's tip should be cleaned regularly with a dry cloth; otherwise, it may cause fire.
- Refrigerator may move if adjustable legs are not properly secured on the floor. Properly securing adjustable legs on the floor can prevent the refrigerator to move.
- When carrying the refrigerator, do not hold it from door handle. Otherwise, it may be snapped.
- When you have to place your product next to another refrigerator or freezer, the distance between devices should be at least 8cm. Otherwise, adjacent side walls may be humidified.

For products with a water dispenser;

Pressure of water mains should be minimum 1 bar. Pressure of water mains should be maximum 8 bars.

- Use only potable water.

Child safety

- If the door has a lock, the key should be kept away from reach of children.
- Children must be supervised to prevent them from tampering with the product.

Compliance with WEEE Directive and Disposing of the Waste Product

This product complies with EU WEEE Directive (2012/19/EU). This product bears a classification symbol for waste electrical and electronic equipment

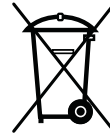

.(WEEE
 This product has been manufactured with high quality parts and materials which can be reused and are suitable for recycling. Therefore, do not dispose the product with normal domestic waste at the end of its service life. Take it to a collection point for the recycling of electrical and electronic equipment. Please consult your local authorities to learn the nearest collection point. Help protect the environment and natural resources by recycling used products. For children's safety, cut the power cable and break the locking mechanism of the door, if any, so that it will be non-functional before disposing of the product.

Package information

Packaging materials of the product are manufactured from recyclable materials in accordance with our National Environment Regulations. Do not dispose of the packaging materials together with the domestic or other wastes. Take them to the packaging material collection points designated by the local authorities.

Do not forget...

Any recycled substance is an indispensable matter for nature and our national asset wealth.

If you want to contribute to the re-evaluation of the packaging materials, you can consult to your environmentalist organizations or the municipalities where you are located.

HCA warning

If your product's cooling system contains R600a:

This gas is flammable. Therefore, pay attention to not damaging the cooling system and piping during usage and transportation. In the event of damage, keep your product away from potential fire sources that can cause the product catch a fire and ventilate the room in which the unit is placed.

Ignore this warning if your product's cooling system contains R134a.

Type of gas used in the product is stated in the type label which is on the left wall inside the refrigerator.

Never throw the product in fire for disposal.

Things to be done for energy saving

- Do not leave the doors of your refrigerator open for a long time.
- Do not put hot food or drinks in your refrigerator.
- Do not overload your refrigerator so that the air circulation inside of it is not prevented.
- Do not install your refrigerator under direct sunlight or near heat emitting appliances such as ovens, dishwashers or radiators. Keep your refrigerator at least 30cm away from heat emitting sources and at least 5cm from electrical ovens.
- Pay attention to keep your food in closed containers.
- For products with a freezer compartment; You can store maximum amount of food items in the freezer when you remove the shelf or drawer of the freezer. Energy consumption value stated for your refrigerator has been determined by removing freezer shelf or drawer and under maximum load. There is no harm to use a shelf or drawer according to the shapes and size of food to be frozen.
- Thawing frozen food in fridge compartment will both provide energy saving and preserve the food quality.

Recommendations for the fresh food compartment

*optional

- Do not allow the food to touch the temperature sensor in fresh food compartment. To allow the fresh food compartment keep its ideal storage temperature, sensor must not be hindered by food.
- Do not place hot foods in the product.

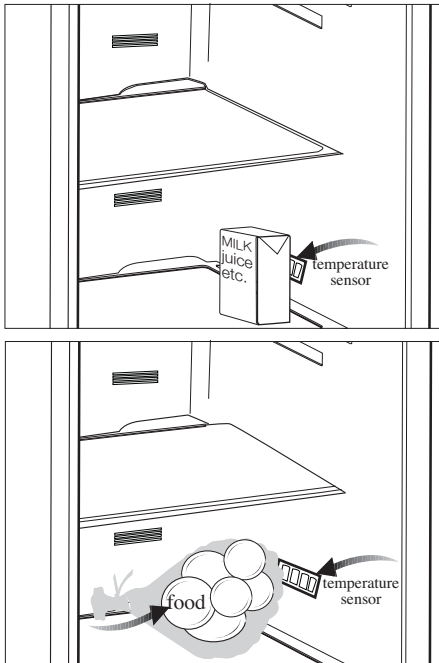

3 Installation

⚠ In case the information which are given in the user manual are not taken into account, manufacturer will not assume any liability for this.

Points to be paid attention to when the relocation of the refrigerator

1. Your refrigerator should be unplugged. Before transportation of your refrigerator, it should be emptied and cleaned.
2. Before it is re-packaged, shelves, accessories, crisper, etc. inside your refrigerator should be fixed with adhesive tape and secured against impacts. Package should be bound with a thick tape or sound ropes and the transportation rules on the package should be strictly observed.
3. Original packaging and foam materials should be kept for future transportations or moving.

Before you start the refrigerator,

Check the following before you start to use your refrigerator:

1. Attach 2 plastic wedges as illustrated below. Plastic wedges are intended to keep the distance which will ensure the air circulation between your refrigerator and the wall. (The picture is drawn up as a representation and it is not identical with your product.)
2. Clean the interior of the refrigerator as recommended in the "Maintenance and cleaning" section.
3. Connect the plug of the refrigerator to the wall socket. When the fridge door is opened, fridge internal lamp will turn on.

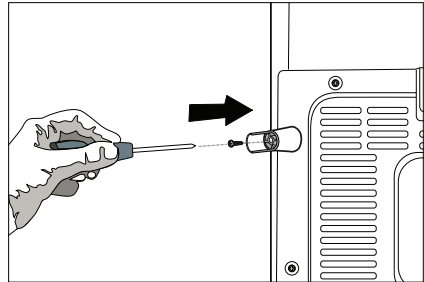
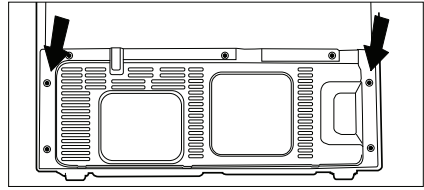

4. When the compressor starts to operate, a sound will be heard. The liquid and gases sealed within the refrigeration system may also give rise to noise, even if the compressor is not running and this is quite normal.
5. Front edges of the refrigerator may feel warm. This is normal. These areas are designed to be warm to avoid condensation.

Electrical connection

Connect your product to a grounded socket which is being protected by a fuse with the appropriate capacity.

Important:

The connection must be in compliance with national regulations.

- The power plug must be easily accessible after installation.
- Electrical safety of your refrigerator shall be guaranteed only if the earth system in your house complies with standards.
- The voltage stated on the label located at left inner side of your product should be equal to your network voltage.

- **Extension cables and multi plugs must not be used for connection.**

- ⚠ A damaged power cable must be replaced by a qualified electrician.
- ⚠ Product must not be operated before it is repaired! There is the risk of electric shock!

Disposing of the packaging

The packing materials may be dangerous for children. Keep the packing materials out of the reach of children or dispose of them by classifying them in accordance with the waste instructions stated by your local authorities. Do not throw away with regular house waste, throw away on packaging pick up spots designated by the local authorities.

The packing of your refrigerator is produced from recyclable materials.

Disposing of your old refrigerator

Dispose of your old refrigerator without giving any harm to the environment.

- You may consult your authorized dealer or waste collection center of your municipality about the disposal of your refrigerator.

Before disposing of your refrigerator, cut out the electric plug and, if there are any locks on the door, make them inoperable in order to protect children against any danger.

Placing and Installation

⚠ If the entrance door of the room where the refrigerator will be installed is not wide enough for the refrigerator to pass through, then call the authorized service to have them remove the doors of your refrigerator and pass it sideways through the door.

1. Install your refrigerator to a place that allows ease of use.
2. Keep your refrigerator away from heat sources, humid places and direct sunlight.
3. There must be appropriate air ventilation around your refrigerator in order to achieve an efficient operation. If the refrigerator is to be placed in a recess in the wall, there must be at least 5 cm distance with the ceiling and at least 5 cm with the wall. Do not place your product on the materials such as rug or carpet.
4. Place your refrigerator on an even floor surface to prevent jolts.

Adjusting the legs

If your refrigerator is unbalanced;

You can balance your refrigerator by turning its front legs as illustrated in the figure. The corner where the leg exists is lowered when you turn in the direction of black arrow and raised when you turn in the opposite direction. Taking help from someone to slightly lift the refrigerator will facilitate this process.

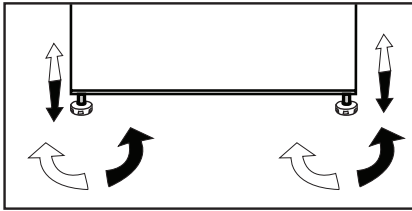

Changing the illumination lamp

To change the Bulb/LED used for illumination of your refrigerator, call your Authorized Service.

Door Open Warning

(This feature is optional)

An audio warning signal will be given when the door of your product is left open for at least 1 minute. This warning will be muted when the door is closed or any of the display buttons (if any) are pressed.

4 Preparation

- Your cooler/freezer should be installed at least 30 cm away from heat sources such as hobs, ovens, central heater and stoves and at least 5 cm away from electrical ovens and should not be located under direct sunlight.
- Please make sure that the interior of your cooler/freezer is cleaned thoroughly.
- If two coolers are to be installed side by side, there should be at least 2 cm distance between them.
- When you operate your cooler/freezer for the first time, please observe the following instructions during the initial six hours.
- Its door should not be opened frequently.
- It must be operated empty without placing any food in it.
- Do not unplug your cooler/freezer. If a power failure occurs out of your control, please see the warnings in the “Recommended solutions for the problems” section.
- This product has been designed to function at ambient temperatures up to 43 °C (90 SDgrF). Even if the ambient temperature falls to -15 °C, frozen food in the freezer does not thaw thanks to its Advanced Electronic Temperature Control System. For the first installation, the product should NOT be placed under low ambient temperatures. This is because the freezer cannot go down to standard operation temperature. When reaching continuous operation, the product can be moved to another place. Thus, later you can place your product in the garage or an unheated room without the concern of causing frozen food to get rotten. However, it is likely that above mentioned low temperatures may cause the freezing of the food in the fridge compartment; thus, please consume the food items in the fridge in a controlled way as needed. When ambient temperature goes back to normal, you may change button setting according to your need.
- If the ambient temperature is below 0°C, the food in fridge compartment will freeze. Therefore, we recommend not using the fridge compartment in such low ambient temperatures. You may continue to use the freezer compartment as usual.

5 Using your refrigerator

Indicator Panel

Indicator panels may vary depending on your product's model.

The Indicator panel aids in using your refrigerator with its audio and visual functions.
(in some models)

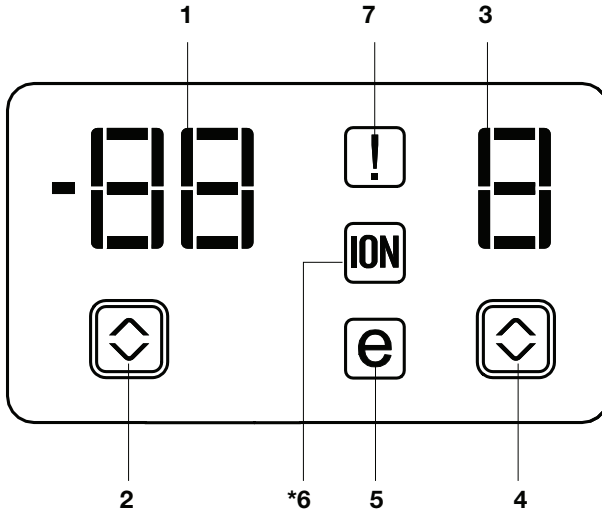

1. Freezer Compartment Temperature Setting Indicator
2. Freezer Compartment Temperature Setting Button
3. Fridge Compartment Temperature Setting Indicator
4. Fridge Compartment Temperature Setting Button
5. Economy Mode Indicator
6. Ionizer Indicator
7. Error Status Indicator

***optional**

i Figures in this user manual are schematic and may not correspond exactly to your product. If the subject parts are not included in the product you have purchased, then it is valid for other models.

1. Freezer Compartment Temperature Setting Indicator

Indicates the temperature set for freezer compartment.

2. Freezer Compartment Temperature Setting Button

Press this button to set the temperature of the freezer compartment to -18, -20, -22, -24, -18... respectively. Press this button to set the desired temperature for the freezer compartment.

3. Fridge Compartment Temperature Setting Indicator

Indicates the temperature set for Fridge compartment.

4. Fridge Compartment Temperature Setting Button

Press this button to set the temperature of the fridge compartment to 8, 6, 4, 2, 8... respectively. Press this button to set the desired temperature for the fridge compartment.

5. Economy Mode Indicator

Indicates that the refrigerator is running in energy-efficient mode.

6- Ionizer Indicator

Indicator light lights up continuously. This light indicates that your refrigerator is protected against the bacteria.

7. Error Status Indicator

If your refrigerator does not cool adequately or if there is a sensor failure, this indicator will be activated. When this indicator is active, Freezer Compartment Temperature indicator will display "e" and Fridge Compartment Temperature Indicator will display numbers such as "1,2,3...". These numbers on the indicator provide information about the error to the service personnel.

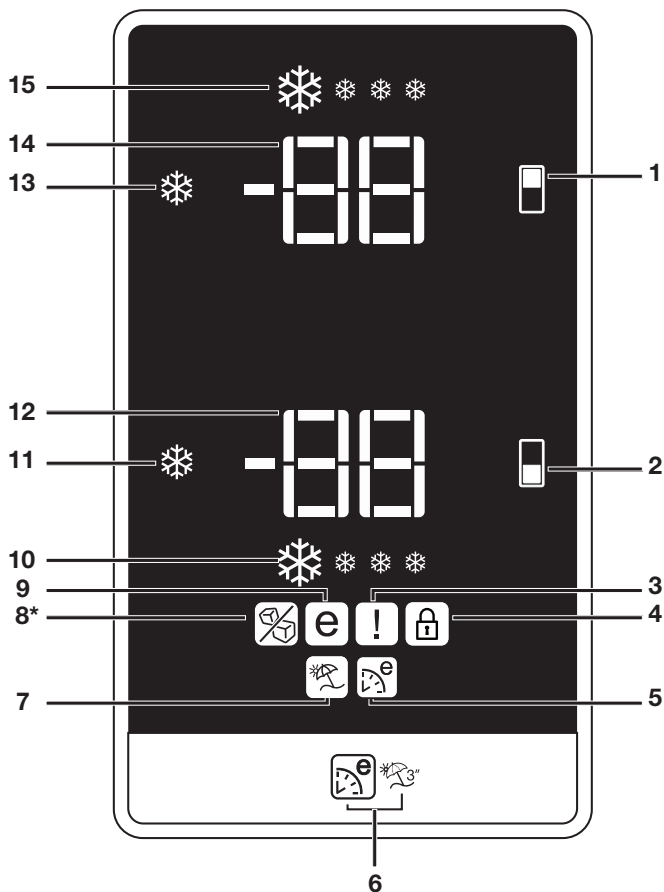

- | | |
|---|--|
| <ul style="list-style-type: none"> 1. Freezer Compartment Temperature Setting Button 2. Fridge Compartment Temperature Setting Button 3. Error Status Indicator 4. Key Lock indicator 5. Eco Extra Function Indicator 6. Eco Extra / Vacation Button 7. Vacation Function Indicator 8. Icematic Off Indicator (*in some models) | <ul style="list-style-type: none"> 9. Economic Usage Indicator 10. Quick Fridge Function Indicator 11. Quick Fridge Function Button 12. Fridge Compartment Temperature Setting Indicator 13. Quick Freeze Function Button Icematic On-Off Button (3") 14. Freezer Compartment Temperature Setting Indicator 15. Quick Freeze Function Indicator <p>*optional</p> |
|---|--|

i Figures in this user manual are schematic and may not correspond exactly to your product. If the subject parts are not included in the product you have purchased, then it is valid for other models.

1. Freezer Compartment Temperature Setting Button

This function allows you to set the temperature of freezer compartment. Press this button to set the temperature of the freezer compartment to -18, -19, -20, -21, -22, -23 and -24, respectively.

2. Fridge Compartment Temperature Setting Button

function allows you to set the fridge compartment's temperature. Press this button to set the temperature of the fridge compartment to 8, 7, 6, 5, 4, 3, 2 degrees, respectively.

3. Error Status Indicator

If your refrigerator does not cool adequately or if there is a sensor failure, this indicator will be activated. When this indicator is active, Freezer Compartment Temperature indicator will display "E" and Fridge Compartment Temperature Indicator will display numbers such as "1,2,3...". These numbers on the indicator provide information about the error to the service personnel.

When you place hot food into the freezer compartment or if you leave the door open for a long time, exclamation mark can illuminate for some time. This is not a failure; this warning will disappear when the food cools down.

4. Key Lock Indicator

Use this function if you do not want your refrigerator temperature setting changed. Press Fridge compartment temperature setting button and Freezer compartment temperature setting button simultaneously for a long time (3 sec) to activate this function.

5. Eco Extra Function Indicator

It indicates that the Eco-Extra function is active.

If this function is active, your refrigerator will automatically detect the least usage periods and energy-efficient cooling will be performed during those times. Economy indicator will be active while energy-efficient cooling is performed.

Press the relevant button again to deactivate this function.

6. Eco Extra/Vacation Button

Press this button briefly to activate the Eco Extra function. Press and hold this button for 3 sec. to activate the Vacation function. Press this button again to deactivate the selected function.

7. Vacation Function Indicator

Indicates that the vacation function is active. If this function is active, "- -" appears on the indicator of the fridge compartment and no cooling is performed in the fridge compartment. Other compartments will continue to be cooled in accordance with the temperature set for them.

Press the relevant button again to deactivate this function.

8. Icematic Off Indicator

Icematic will not run when the indicator of this function is active.

To activate the ice off function, you need to press and hold the quick freeze button for 3 seconds.

9. Economic Usage Indicator

Indicates that the refrigerator is running in energy-efficient mode. This indicator will be active if the Freezer Compartment temperature is set to -18 or the energy efficient cooling is being performed due to Eco-Extra function.

10. Quick Fridge Function Indicator

This symbol flashes in an animated style when the Quick Fridge function is active.

11. Quick Fridge Function Button

When you press the Quick Fridge button, the temperature of the compartment will be colder than the adjusted values.

This function can be used for food placed in the fridge compartment and required to be cooled down rapidly.

If you want to cool large amounts of fresh food, it is recommended to activate this feature before putting the food into the fridge.

Quick Fridge indicator turns on when the Quick Fridge function is on. To cancel this function, press Quick Fridge button again.

If you do not cancel it, Quick Fridge will cancel itself automatically after 4 hours or when the fridge compartment reaches to the required temperature.

This function is not recalled when power restores after a power failure.

12. Fridge Compartment Temperature Setting Indicator

Indicates the temperature set for the Fridge Compartment.

13. Quick Freeze Function Button Icematic On-Off Button (3")

Indicates the temperature set for the Freezer Compartment.

To stop ice formation, press Icematic on-off button for 3 seconds. Water flow from water tank will stop when this function is selected. However, ice made previously can be taken from the Icematic. To restart ice formation, press Icematic on-off button for 3 seconds.

14. Freezer Compartment Temperature Setting Indicator

Fast Freeze indicator turns on when the Fast Freeze function is active. To cancel this function, press Fast Freeze button again. Quick Freeze indicator will turn off and return to its normal settings. If you do not cancel it, Fast Freeze will cancel itself automatically after 8 hours or when the freezer compartment reaches to the required temperature.

If you want to freeze large amounts of fresh food, press the Fast Freeze button before putting the food into the freezer compartment.

If you press the Fast Freeze button repeatedly with short intervals, the electronic circuit protection will be activated and the compressor will not start up immediately.

This function is not recalled when power restores after a power failure.

15. Quick Freeze Function Indicator

This symbol flashes in an animated style when the Fast Freeze function is active.

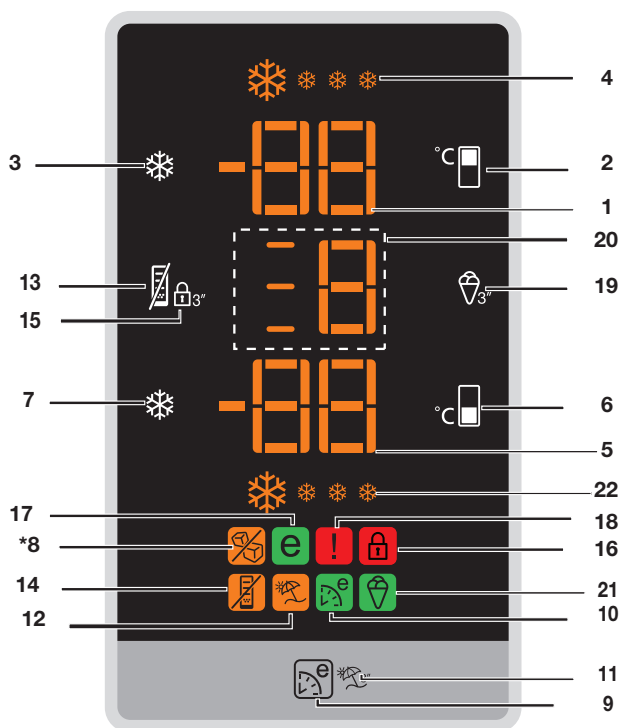

- | | |
|---|--|
| <ul style="list-style-type: none"> 1. Freezer Compartment Temperature Setting Indicator 2. Freezer Compartment Temperature Setting Function 3. Quick Freeze Function Button Icematic On-Off Button (3") 4. Quick Freeze Function Indicator 5. Fridge Compartment Temperature Setting Indicator 6. Fridge Compartment Temperature Setting Function 7. Quick Fridge Function Button 8. Icematic Off Indicator (*in some models) 9. Eco-Fuzzy (Special Economic Usage) Function | <ul style="list-style-type: none"> 10. Eco-Fuzzy (Special Economic Usage) Indicator 11. Vacation Function 12. Vacation Function Indicator 13. Energy Efficiency Function 14. Energy Efficiency Indicator 15. Key Lock Function 16. Key Lock indicator 17. Economic Usage Indicator 18. High Temperature/Error Warning Indicator 19. Ice Cream Mode Selection Function 20. Ice Cream Mode Selection Indicator 21. Ice Cream Indicator 22. Quick Fridge Indicator <p>*optional</p> |
|---|--|

i Figures in this user manual are schematic and may not correspond exactly to you product. If the subject parts are not included in the product you have purchased, then it is valid for other models.

1. Freezer Compartment Temperature Indicator

Indicates the temperature set for Freezer Compartment.

2. Freezer Compartment Temperature Setting Function

This function allows you to set the temperature of freezer compartment. Press this button to set the temperature of the freezer compartment to -18, -19, -20, -21, -22, -23 and -24, respectively.

3. Quick Freeze Function Button Icematic On-Off Button (3")

Quick Freeze indicator is illuminated when the Quick Freeze function is active. To cancel this function, press Quick Freeze button again. Quick Freeze indicator will turn off and return to its normal settings. If you do not cancel it, Quick Freeze will cancel itself automatically after 4 hours or when the freezer compartment reaches the required temperature. If you want to freeze large amounts of fresh food, press the Quick Freeze button before putting the food into the freezer compartment. If you press the Quick Freeze button repeatedly with short intervals, the electronic circuit protection will be activated and the compressor will not start up immediately. This function is not recalled when power restores after a power failure!

4. Quick Freeze Function Indicator

This symbol flashes in an animated style when the Quick Freeze function is active.

5. Fridge Compartment Temperature Setting Indicator

Indicates the temperature set for the Fridge Compartment.

6. Fridge Compartment Temperature Setting Function

function allows you to set the fridge compartment's temperature. Press this button to set the temperature of the fridge

compartment to 8, 7, 6, 5, 4, 3, 2 degrees, respectively.

7. Quick Fridge Function Button

When you press the Quick Fridge button, the temperature of the compartment will be colder than the adjusted values. This function can be used for food required to be cooled down rapidly in the fridge compartment. If you want to cool large amounts of fresh food, it is recommended to activate this function before putting the food into the fridge. Quick Fridge indicator is illuminated when the Quick Fridge function is active. To cancel this function, press Quick Fridge button again. Quick Fridge indicator will turn off and return to its normal settings. If you do not cancel it, Quick Fridge function will cancel itself automatically after 2 hours or when the fridge compartment reaches the required temperature.

This function is not recalled when power restores after a power failure.

8. Icematic Off Indicator

Icematic will not run when the indicator of this function is active.

To activate the ice off function, you need to press and hold the quick freeze and quick fridge buttons for 3 seconds.

9. Eco-Fuzzy (Special Economic Usage) Function

When you press Eco-Fuzzy button, Eco Fuzzy Function will be activated and Eco-Fuzzy Indicator will illuminate. Refrigerator will start operating in the most economic mode at least 6 hours later and the economic usage indicator will turn on when the function is active. To deactivate the Eco Fuzzy function, You need to press on the Eco-Fuzzy button again.

10. Eco-Fuzzy (Special Economic Usage) Indicator

This symbol illuminates when the Eco-Fuzzy Function is active.

11. Vacation Function

Press and hold Eco Fuzzy button for 3 seconds to activate Vacation Function and illuminate Vacation Indicator. The cooling of Fridge Compartment is stopped and temperature of Fridge Compartment is fixed to 15 degrees to prevent bad odors. When this function is active, Fridge Compartment Temperature Indicator will not display the temperature. To deactivate Vacation Function, press and hold Eco-Fuzzy button for 3 seconds.

12. Vacation Function Indicator

This indicator illuminates when Vacation Function is active.

13. Energy Saving Function

When you press Energy Efficiency button, Energy Efficiency Function will be activated and Energy Efficiency Indicator will illuminate. When Energy Efficiency Function is active, all indicators, except for Energy Efficiency Indicator, will turn off. This function will be deactivated when any button is pressed or door is opened; display indicators will return normal settings and Energy Efficiency Indicator will stay illuminated. If you do not press any button or open the door within 5 minutes when Energy Efficiency Indicator is still illuminated, Energy Efficiency Function will be activated again and display indicators will turn off. If you press Energy Efficiency button when the function is not active but the indicator is still illuminated, this will deactivate Energy Efficiency function and turn off Energy Efficiency Indicator.

14. Energy Saving Indicator

This indicator illuminates when Energy Efficiency Function is selected.

15. Key Lock Function

When you press and hold Key Lock button for 3 seconds, Key Lock Function will be activated and Key Lock Indicator will illuminate. No button will operate when this function is active. Press and hold Key Lock button for 3 seconds again to deactivate this function.

16. Key Lock Indicator

This indicator will illuminate when Key Lock Function is active.

17. Economic Usage Indicator

Economic Usage Indicator turns on when the Freezer Compartment is set to -18°C. When Quick Freeze or Quick Fridge is selected, Economic Usage Indicator will not illuminate.

18. High Temperature/Error Warning Indicator

This light illuminates during high temperature failures and error warnings.

19. Ice Cream Mode Selection Function

When the Ice Cream button is pressed for 3 seconds; it will flash.

If this button is not pressed again in 30 seconds, display will return to its previous view, Ice Cream mode selection indicators will turn off.

With every short press of the Ice Cream button, the number will increase by one.

When the Ice Cream button is pressed again for 3 seconds, Ice Cream symbol on the display will turn on again. Thus, Ice Cream mode is selected and the number will turn on solid while the symbols on the left side will illuminate with animations.

When the Ice Cream process is completed, the symbols start to flash and an audio warning is given. All Ice Cream symbols will turn off after this 5-minute warning.

Just press the Ice Cream button briefly to terminate the audio warning; Ice Cream buttons will turn off too.

If the Ice Cream button is pressed briefly when the Ice Cream process is in progress, no change will take place on the display.



When the Ice Cream Function is active, if a power cut occurs and then power is resumed again, Ice Cream process will be maintained from where it is interrupted.

If the Ice Cream function is tried to be activated when the freezer compartment is at a temperature higher than -10°C , 'E' and the warning symbol on the display will flash for 30 seconds. If the user presses the Ice Cream function selection button briefly (for 3 seconds), display will return to its normal Ice Cream view, Ice Cream symbol and warning symbol will turn off.

20. Ice Cream Mode Selection Function

It shows the set Ice Cream mode.

21. Ice Cream Indicator

It turns on when the Ice Cream mode is activated.

22. Quick Fridge Indicator

This symbol flashes in an animated style when the Quick Fridge function is active.

*Optional

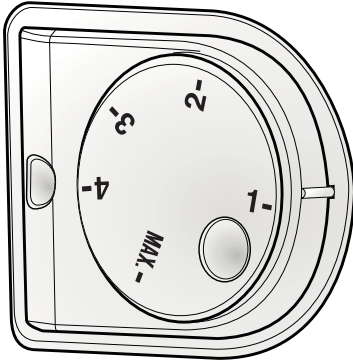

Dual cooling system

Your refrigerator is equipped with two separate cooling systems to cool the fresh food compartment and freezer compartment. Thus, air in the fresh food compartment and freezer compartment do not get mixed. Thanks to these two separate cooling systems, cooling speed is much higher than other refrigerators. Odors in the compartments do not get mixed. Also additional power saving is provided since the automatic defrosting is performed individually.

Temperature setting button

Temperature Setting button allows you to make the temperature setting of your refrigerator.

Setting the temperature of your refrigerator

The overall temperature setting of your refrigerator is made by means of the temperature setting button on the right wall of the fridge compartment. This button has 5 different temperature setting position. Select the position suitable to your needs.

Level number 1 shows when the fridge is at its hottest and the max position shows its coldest setting.

- Hot food must cool down to the room temperature before putting them in the refrigerator.
- The foodstuff that you want to freeze must be fresh and in good quality.
- Foodstuff must be divided into portions according to the family's daily or meal based consumption needs.
- Foodstuff must be packaged in an airtight manner to prevent them from drying even if they are going to be kept for a short time.
- Materials to be used for packagings must be resistant to cold and humidity and they must be airtight. The packaging material of the food must be at a sufficient thickness and durability. Otherwise the food hardened due to freezing may puncture the packaging. It is important for the packaging to be closed securely for safe storage of the food.

ⓘ Figures in this user manual are schematic and may not correspond exactly to your product. If the subject parts are not included in the product you have purchased, then it is valid for other models.

- Frozen food must be used immediately after they are thawed and they should never be re-frozen.
 - Please observe the following instructions to obtain the best results.
1. If the fridge has a quick freeze function, activate the quick freeze function when you want to freeze the food.

2. Do not freeze too large quantities of food at one time. The quality of the food is best preserved when it is frozen right through to the core as quickly as possible.
3. Take special care not to mix already frozen food and fresh food.
4. Make sure raw foods are not in contact with cooked foods in the fridge.

Freezer Compartment Setting	Fridge Compartment Setting	Remarks
-18°C	4°C	This is the normal recommended setting.
-20, -22 or -24°C	4°C	These settings are recommended when the ambient temperature exceeds 30°C.
Quick Freeze	4°C	Use when you wish to freeze your food in a short time. It is recommended to be used to maintain the quality of meat and fish products.
-18°C or colder	2°C	If you think that your fridge compartment is not cold enough because of the hot conditions or frequent opening and closing of the door.
-18°C or colder	Quick Fridge	You can use it when your fridge compartment is overloaded or if you wish to cool down your food rapidly. It is recommended that you activate the quick freeze function 4-8 hours before placing the food.

Recommendations for preservation of frozen food

- Pre-packed commercially frozen food should be stored in accordance with the frozen food manufacturer's instructions in a frozen food storage compartment.
- To ensure that the high quality supplied by the frozen food manufacturer and the food retailer is maintained, following points should be noted:
 1. Put packages in the freezer as quickly as possible after purchase.
 2. Ensure that contents of the package are labeled and dated.

3. Do not exceed "Use By", "Best Before" dates on the packaging.

Defrosting

The freezer compartment defrosts automatically.

Placing the food

Freezer compartment shelves	Various frozen food such as meat, fish, ice cream, vegetables and etc.
Egg section	Egg

Fridge compartment shelves	Food in pans, covered plates and closed containers
Door shelves of fridge compartment	Small and packaged food and drinks (such as milk, fruit juice and beer)
Crisper	Vegetables and fruits
Freshzone compartment	Delicatessen products (cheese, butter, salami and etc.)

Deep-freeze information

Food must be frozen as rapidly as possible when they are put in the freezer in order to keep them in good quality.

The TSE norm requires (according to certain measurement conditions) the refrigerator to freeze at least 4.5 kg of foodstuff at 32°C ambient temperature to -18°C or lower within 24 hours for every 100-liters of freezer volume.

It is possible to preserve the food for a long time only at -18°C or lower temperatures.

You can keep the freshness of food for many months (at -18°C or lower temperatures in the deep freeze).

WARNING! ⚠

- Foodstuff must be divided into portions according to the family's daily or meal based consumption needs.

- Foodstuff must be packaged in an airtight manner to prevent them from drying even if they are going to be kept for a short time.

Materials necessary for packaging:

- Cold resistant adhesive tape
- Self-adhesive label
- Rubber rings
- Pen

Materials to be used for packaging the foodstuff must be tear-proof and resistant to cold, humidity, dour, oils and acids.

Foodstuff to be frozen should not be allowed to come in contact with the previously frozen items to prevent their partial thawing. Thawed out food must be consumed and must not be frozen again.

Egg section

You can place the egg section in any of the door shelves. If it is going to be placed in the body, the lower shelves are recommended due them being cooler.

Never store eggs in the freezer compartment.

Avoid direct contact between eggs and other foods.

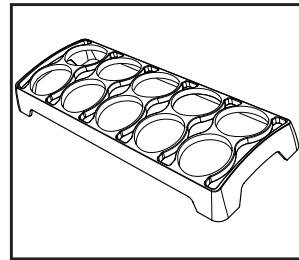

Description and cleaning of odor filter:

*optional

Odor filter prevents unpleasant odor build-up in your refrigerator.

Pull the cover into which the odor filter is installed downwards from the front section and remove as illustrated. Leave the filter under sunlight for one day. Filter will be cleaned during this time. Install the filter back to its place.

Odor filter must be cleaned once in a year.

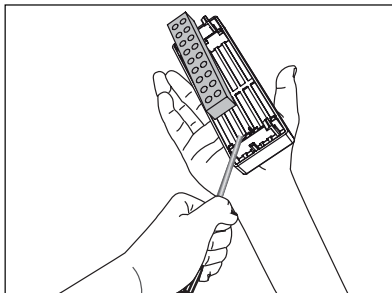
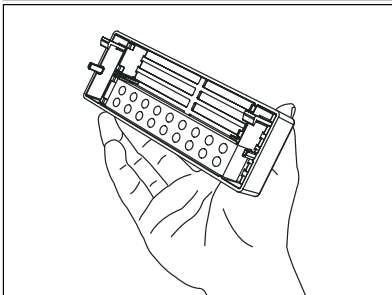
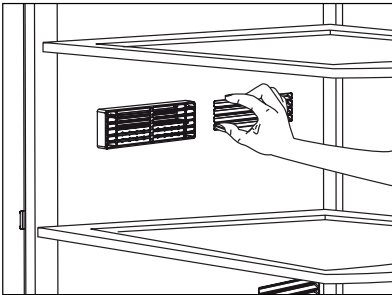

Breakfast Compartment

Because products such as fish, red meat, chicken meat, and dairy products such as cheese, yoghurt and milk need to be kept in an ambient a few degrees cooler than the fridge compartment, it is recommended to store these goods in the breakfast compartment. It is not recommended to place fruit and vegetables in the breakfast compartment. Especially tomatoes, eggplants, zucchinis, cucumbers and lemons are sensitive to the cold. They should not be stored in the breakfast compartment.

You can increase the inner volume of your refrigerator by removing the breakfast compartment.

1. Pull the compartment towards yourself until it rests and stops against the stopper.
2. Lift the front section and pull towards yourself to remove the compartment from its seating.

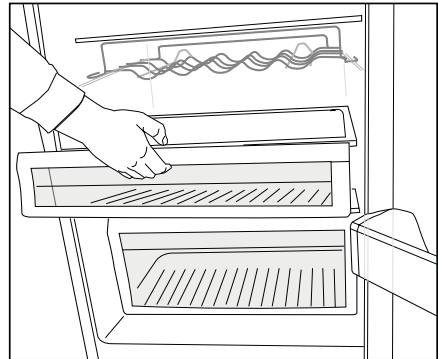

Water Dispenser

*optional

Water dispenser is a very useful feature based on reaching cold water without opening the door of your refrigerator. As you will not have to open your refrigerator door frequently, you will have saved energy.

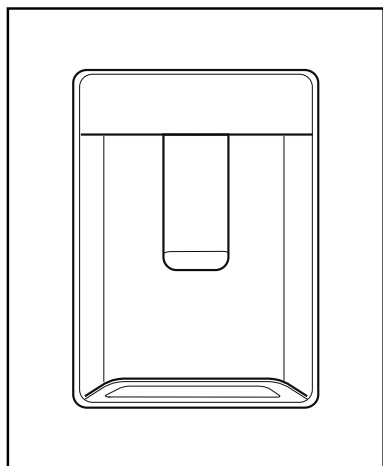

Using the water dispenser

Push the arm of the water dispenser with your glass. The dispenser will cease operating once you release the arm.

When operating the water dispenser, maximum flow can be obtained by pressing the arm fully. Please remember that the amount of flow from the dispenser is subject to the degree you press the arm.

As the level of the water in your glass/container rises, slightly lessen the pressure on the arm to prevent the overspill. If you slightly press the arm, the water will drip; this is quite normal and not a failure.

Filling the water dispenser's tank

Water tank filling reservoir is located inside the door rack. You can open the reservoir cover and fill it with potable water. And then, close the lid.

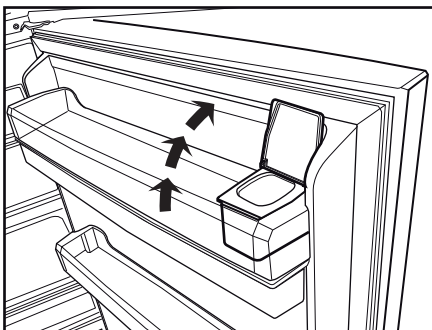
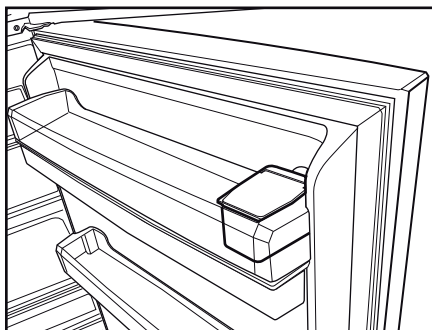

Warning!

- Do not fill the water tank with any liquid other than water, such as fruit juices, milk, carbonated beverages or alcoholic drinks which are not suitable to use in the water dispenser. Water dispenser will be irreparably damaged if these kinds of liquids are used. Warranty does not cover such usages. Some chemical substances and additives contained in these kinds of drinks/liquids may damage the water tank and its materials.

- Use clean drinking water only.
- Capacity of the water tank is 3 liters; do not overfill.
- Push the arm of the water dispenser with a rigid glass. If you are using disposable plastic glasses, push the arm with your fingers from behind the glass.

Cleaning the water tank

- Remove the water filling reservoir inside the door rack.
- Remove the door rack by holding from both sides.
- Grab the water tank from both sides and remove it with an angle of 45°.
- Clean the water tank by removing its lid.

Important:

Components of the water tank and water dispenser should not be washed in dishwasher.

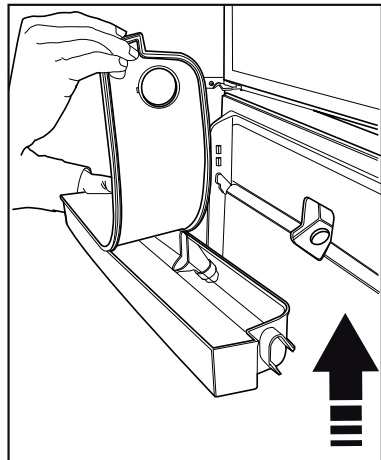
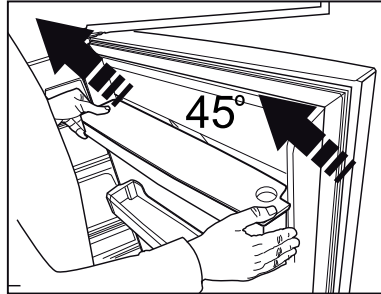
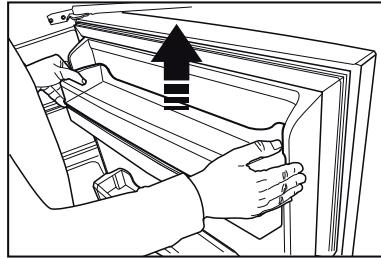
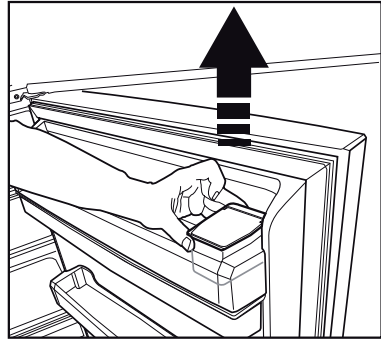

Water tray

Water that dripped while using the water dispenser accumulates in the spillage tray.

Take out the plastic strainer as shown in the figure.

With a clean and dry cloth, remove the water that has accumulated.

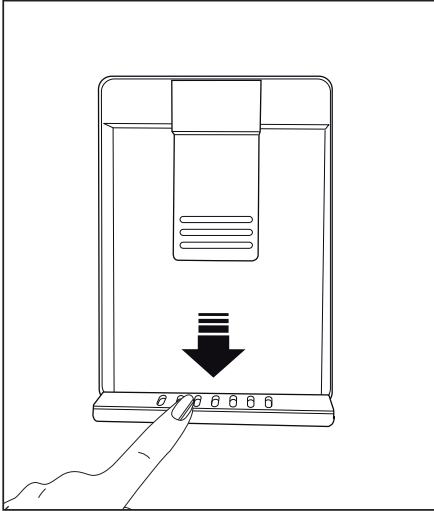

Blue light

***optional**

Foodstuff stored in the crispers that are enlightened with a blue light continue their photosynthesis by means of the wavelength effect of blue light and thus, preserve their freshness and increase their vitamin content.

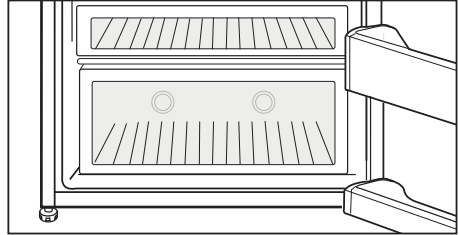

Sliding storage container

***optional**

This accessory is designed to increase the usage volume of the door shelves. It allows you to easily place the tall bottles, jars and tins to the lower bottle shelf thanks to its ability to move right or left.

(The illustrated figure is only an example and does not match exactly with your product.)

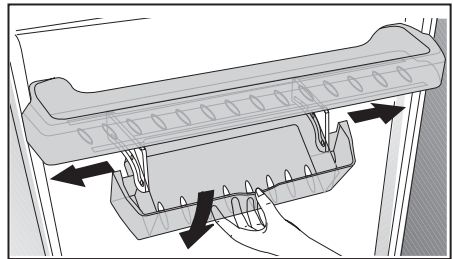

Rotary storage container

(in some models)

Sliding body shelf can be moved to left or right in order to allow you place the tall bottles, jars or boxes to the lower shelf (Fig. 1)

You can reach the food that you have placed into the shelf by grabbing and turning it from its right edge (Fig.2).

When you want to load or remove it to clean, turn it by 90 degrees, raise it up and pull towards yourself (Fig. 3-4).

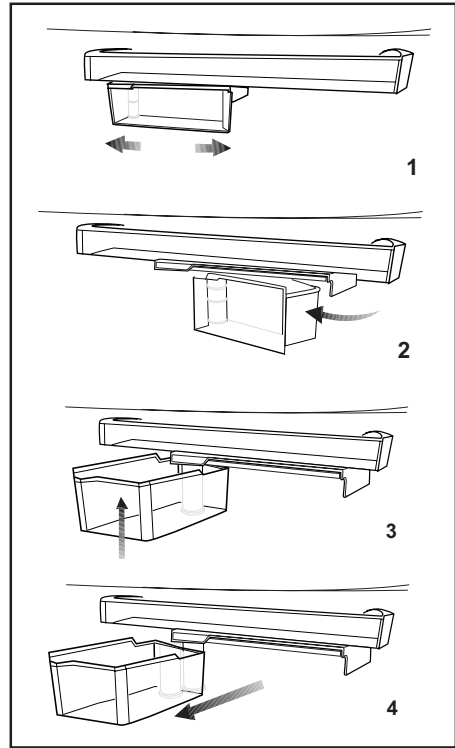

Auto Icematic

*optional

The Auto Icematic allows you to make ice in the fridge easily. Remove the water tank in the fridge compartment, fill it with water and install it back to obtain ice from the Icematic.

First ice cubes will be ready in approximately 2 hours in the Icematic drawer located in the freezer compartment.

If you fill the water tank completely, you will be able to obtain approximately 60-70 ice cubes.

Change the water in water tank if it has waited around 2-3 weeks.

Note: For the products having automatic Icematic, sound may be heard during ice pouring. This sound is normal and does not signal any error.

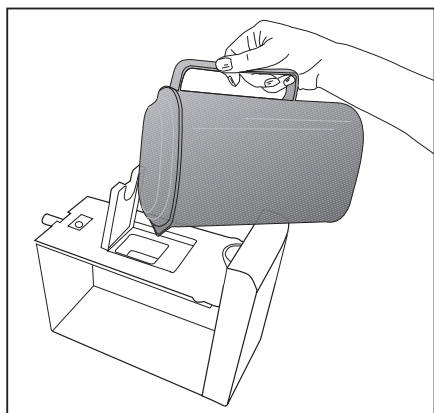
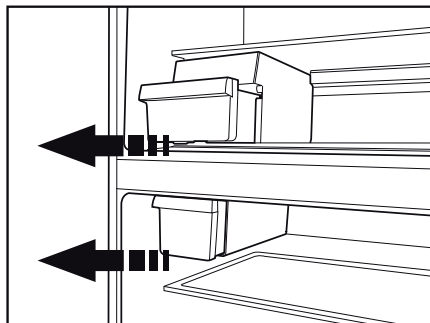

Icematic and ice storage container

***optional**

Using the Icematic

Fill the Icematic with water and place it into its seat. Your ice will be ready approximately in two hours. Do not remove the Icematic from its seating to take ice.

Turn the knobs on the ice reservoirs clockwise by 90 degrees.

Ice cubes in the reservoirs will fall down into the ice storage container below.

You may take out the ice storage container and serve the ice cubes.

If you wish, you may keep the ice cubes in the ice storage container.

Ice storage container

Ice storage container is only intended for accumulating the ice cubes. Do not put water in it. Otherwise, it will break.

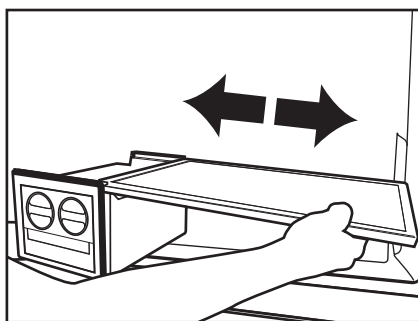
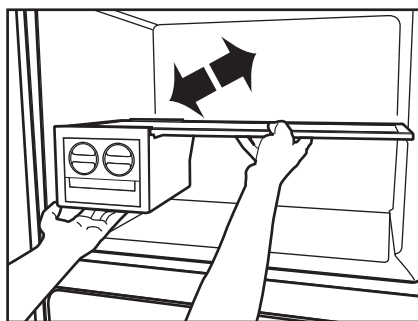
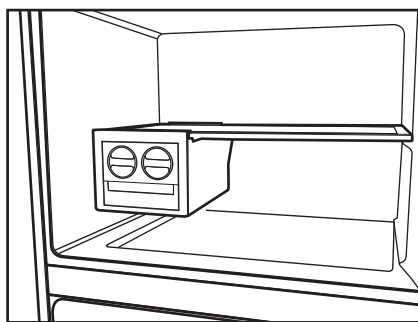
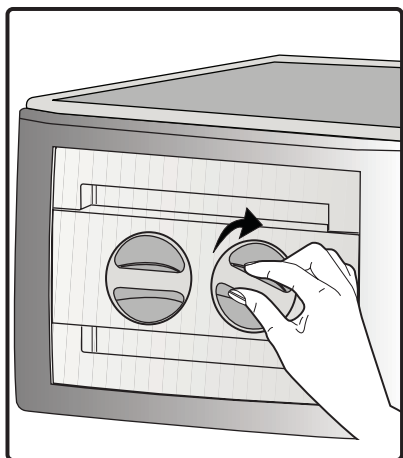

Making ice

*optional

Fill the ice container with water and place it into the freezer compartment. Your ice will be ready approximately in two hours.

You can remove the ice in the ice container by removing it from the freezer and twisting it.

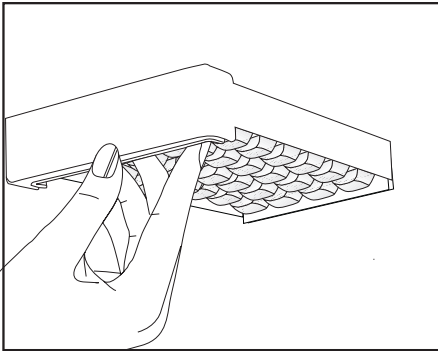

Humidity-controlled crisper (Ever Fresh)

*optional

Humidity rates of the vegetables and fruit are kept under control with the feature of humidity-controlled crisper and the food is ensured to stay fresh for longer.

Humidity setting slides which are located at the front of the crisper cover make sure that the humidity level in the crisper is controlled depending on the vegetable and fruit contained in the crisper. Keep the fruit such as orange, lemon, grapefruit, avocado, pineapple (uncut), quince and the vegetables such as onion, garlic and potato at a low level of humidity. Vegetables and fruit apart from these should be kept at a high level of humidity in order to reduce the humidity loss and extend their shelf life. If condensation is observed on the surface of the crisper when the crisper is overloaded with leafy vegetables with large surfaces or vegetables such as cucumber that loses its humidity quickly, then open the slide flaps.

The position in which the openings are fully open is the low humidity position. When it is closed, it is at high level of humidity.

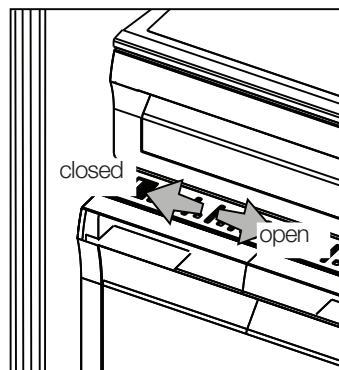

Never block the air vents which are located in front of the slide flaps on the front side of the crisper cover.

To prevent condensation, vegetables should be avoided to contact the ceiling of the crisper as much as possible and the ceiling openings should not be blocked.

Place the leafy vegetables such as lettuce, spinach and the vegetables which are sensitive to humidity loss, in a horizontal manner as much as possible inside the crisper, not on their roots in a vertical position.

Never leave the vegetables inside the crisper in their bags. If the vegetables are left inside their bags, this will cause them to decompose in a short period of time. When a high level of humidity is set, your vegetables keep their humidity content and can be preserved for a reasonable period of time without needing to leave them inside their bags. In case contacting with other vegetables is not preferred for hygiene concerns, use a perforated paper, foam and other similar packaging materials instead of a bag.

While the vegetables are being placed, specific gravity of the vegetables should be taken into consideration. Heavy and hard vegetables should be put at the bottom of the crisper and the lightweight and soft vegetables should be placed over.

Do not place together the pear, apricot, peach, etc. and apple in particular which have a high level of generation of ethylene gas in the same crisper with the other vegetables and fruit. The ethylene gas which is emitted by these fruit may cause the other fruit to ripen faster and decompose in a shorter time.

Do not take the crisper main body out of the refrigerator apart from the drawers unless you have to, and call for technical service if necessary. Before removing the crisper main body from its place, wipe and clean it with a wet piece of cloth.

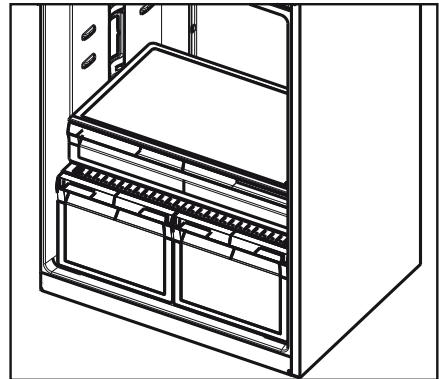

Ice-cream machine

*optional

- Open the freezer compartment of the refrigerator,
- Push and release open the cover of the ice-cream making compartment in the freezer compartment,

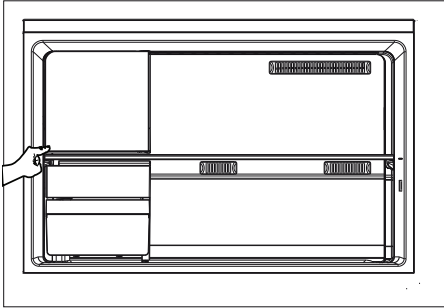

- Place the fresh freeze tray inside the base cover and slide it into the highest shelf inside the compartment,

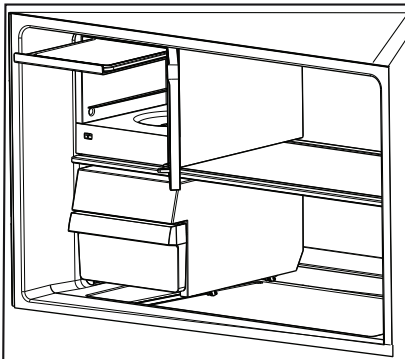

- Take the ice-cream mix which is cooled to room temperature to the ice-cream making container,

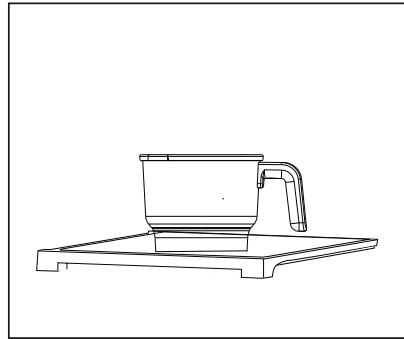

- The ice-cream mix which will be placed in the ice cream boxes must not exceed the amount stated in the ice cream recipes. If more ice cream mix is placed in the boxes than indicated in the recipe, it will overflow.
- Place the container into the housing at the bottom of the compartment towards the left side.
- Turn the container to the right side and lock it into its place.

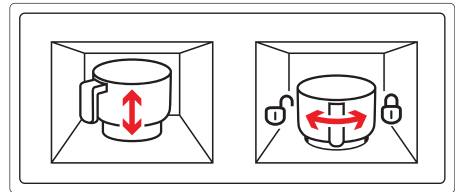

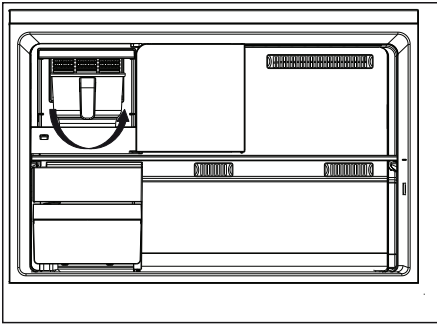

- Close the cover of the ice-making compartment, push and release to lock it.
- Close the door of the freezer compartment.
- i** You can determine the ice cream mode from the ice cream recipe book.
- i** Set the ice cream mode depending on the ice cream type from the display on the door.
- i** Do not wash the ice cream making container in the dishwasher.
- i** During the ice cream making process, the fridge, depending on the current working conditions, will work with a slight noise for a while.

6 Maintenance and cleaning

- ⚠ Never use gasoline, benzene or similar substances for cleaning purposes.
- ⚠ We recommend that you unplug the appliance before cleaning.
- ⚠ Never use any sharp abrasive instrument, soap, household cleaner, detergent and wax polish for cleaning.
- ℹ Use lukewarm water to clean the cabinet of your refrigerator and wipe it dry.
- ℹ Use a damp cloth wrung out in a solution of one teaspoon of bicarbonate of soda to one pint of water to clean the interior and wipe it dry.
- ⚠ Make sure that no water enters the lamp housing and other electrical items.
- ⚠ If your refrigerator is not going to be used for a long period of time, unplug the power cable, remove all food, clean it and leave the door ajar.
- ℹ Check door seals regularly to ensure they are clean and free from food particles.
- ⚠ To remove door racks, remove all the contents and then simply push the door rack upwards from the base.
- ⚠ Never use cleaning agents or water that contain chlorine to clean the outer surfaces and chromium coated parts of the product. Chlorine causes corrosion on such metal surfaces.

Protection of plastic surfaces

- ℹ Do not put the liquid oils or oil-cooked meals in your refrigerator in unsealed containers as they damage the plastic surfaces of your refrigerator. In case of spilling or smearing oil on the plastic surfaces, clean and rinse the relevant part of the surface at once with warm water.

7 Troubleshooting

Please review this list before calling the service. It will save your time and money. This list includes frequent complaints that are not arising from defective workmanship or material usage. Some of the features described here may not exist in your product.

The refrigerator does not operate.
<ul style="list-style-type: none">• The plug is not inserted into the socket correctly. >>>Insert the plug into the socket securely.• The fuse of the socket which your refrigerator is connected to or the main fuse have blown out. >>>Check the fuse.
Condensation on the side wall of the fridge compartment (MULTIZONE, COOL CONTROL and FLEXI ZONE).
<ul style="list-style-type: none">• Ambient is very cold. >>>Do not install the refrigerator in places where the temperature falls below 10 °C.• Door has been opened frequently. >>>Do not open and close the door of refrigerator frequently.• Ambient is very humid. >>>Do not install your refrigerator into highly humid places.• Food containing liquid is stored in open containers. >>>Do not store food with liquid content in open containers.• Door of the refrigerator is left ajar. >>>Close the door of the refrigerator.• Thermostat is set to a very cold level. >>>Set the thermostat to a suitable level.
Compressor is not running
<ul style="list-style-type: none">• Protective thermic of the compressor will blow out during sudden power failures or plug-out plug-ins as the refrigerant pressure in the cooling system of the refrigerator has not been balanced yet. The refrigerator will start running approximately after 6 minutes. Please call the service if the refrigerator does not startup at the end of this period.• The fridge is in defrost cycle. >>>This is normal for a full-automatically defrosting refrigerator. Defrosting cycle occurs periodically.• The refrigerator is not plugged into the socket. >>>Make sure that the plug is fit into the socket.• Temperature settings are not made correctly. >>>Select the suitable temperature value.• There is a power outage. >>>Refrigerator returns to normal operation when the power restores.
The operation noise increases when the refrigerator is running.
<ul style="list-style-type: none">• The operating performance of the refrigerator may change due to the changes in the ambient temperature. It is normal and not a fault.
The refrigerator is running frequently or for a long time.

- New product may be wider than the previous one. Larger refrigerators operate for a longer period of time.
- The room temperature may be high. >>>It is normal that the product operates for longer periods in hot ambient.
- The refrigerator might be plugged in recently or might be loaded with food. >>>When the refrigerator is plugged in or loaded with food recently, it will take longer for it to attain the set temperature. This is normal.
- Large amounts of hot food might be put in the refrigerator recently. >>>Do not put hot food into the refrigerator.
- Doors might be opened frequently or left ajar for a long time. >>>The warm air that has entered into the refrigerator causes the refrigerator to run for longer periods. Do not open the doors frequently.
- Freezer or fridge compartment door might be left ajar. >>>Check if the doors are closed completely.
- The refrigerator is adjusted to a very low temperature. >>>Adjust the refrigerator temperature to a warmer degree and wait until the temperature is achieved.
- Door seal of the fridge or freezer may be soiled, worn out, broken or not properly seated. >>>Clean or replace the seal. Damaged/broken seal causes the refrigerator to run for a longer period of time in order to maintain the current temperature.

Freezer temperature is very low while the fridge temperature is sufficient.

- The freezer temperature is adjusted to a very low value. >>>Adjust the freezer temperature to a warmer degree and check.

Fridge temperature is very low while the freezer temperature is sufficient.

- The fridge temperature is adjusted to a very low value. >>>Adjust the fridge temperature to a warmer degree and check.

Food kept in the fridge compartment drawers is frozen.

- The fridge temperature is adjusted to a very high value. >>>Adjust the fridge temperature to a lower value and check.

Temperature in the fridge or freezer is very high.

<ul style="list-style-type: none"> • The fridge temperature is adjusted to a very high value. >>>Fridge compartment temperature setting has an effect on the temperature of the freezer. Change the temperatures of the fridge or freezer and wait until the relevant compartments attain a sufficient temperature. • Doors are opened frequently or left ajar for a long time. >>>Do not open the doors frequently. • Door is ajar. >>>Close the door completely. • The refrigerator is plugged in or loaded with food recently. >>>This is normal. When the refrigerator is plugged in or loaded with food recently, it will take longer for it to attain the set temperature. • Large amounts of hot food might be put in the refrigerator recently. >>>Do not put hot food into the refrigerator.
<ul style="list-style-type: none"> • Vibrations or noise.
<ul style="list-style-type: none"> • The floor is not level or stable. >>> If the refrigerator rocks when moved slowly, balance it by adjusting its feet. Also make sure that the floor is strong enough to carry the refrigerator, and level. • The items put onto the refrigerator may cause noise. >>>Remove the items on top of the refrigerator.
There are noises coming from the refrigerator like liquid flowing, spraying, etc.
<ul style="list-style-type: none"> • Liquid and gas flows occur in accordance with the operating principles of your refrigerator. It is normal and not a fault.
Whistle comes from the refrigerator.
<ul style="list-style-type: none"> • Fans are used in order to cool the refrigerator. It is normal and not a fault.
Condensation on the inner walls of refrigerator.
<ul style="list-style-type: none"> • Hot and humid weather increases icing and condensation. It is normal and not a fault. • Doors are opened frequently or left ajar for a long time. >>>Do not open the doors frequently. Close them if they are open. • Door is ajar. >>>Close the door completely.
Humidity occurs on the outside of the refrigerator or between the doors.
<ul style="list-style-type: none"> • There might be humidity in the air; this is quite normal in humid weather. When the humidity is less, condensation will disappear.
Bad odour inside the refrigerator.

- No regular cleaning is performed. >>>Clean the inside of the refrigerator regularly with a sponge, lukewarm water or carbonate dissolved in water.
- Some containers or package materials may cause the smell. >>>Use a different container or different brand packaging material.
- Food is put into the refrigerator in uncovered containers. >>>Keep the food in closed containers. Microorganisms spreading out from uncovered containers can cause unpleasant odours.
- Remove the foods that have expired best before dates and spoiled from the refrigerator.

The door is not closing.

- Food packages are preventing the door from closing. >>>Replace the packages that are obstructing the door.
- The refrigerator is not completely even on the floor. >>>Adjust the feet to balance the refrigerator.
- The floor is not level or strong. >>>Make sure that the floor is level and capable to carry the refrigerator.

Crispers are stuck.

- The food is touching the ceiling of the drawer. >>>Rearrange food in the drawer.

